



RUTX08

Quick Start Guide v2.3



Wiki knowledge base

<https://wiki.teltonika-networks.com/>



FRONT VIEW

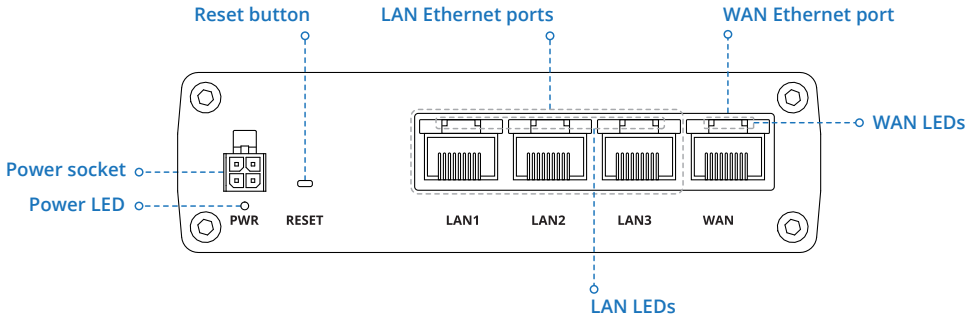

BACK VIEW



POWER SOCKET PINOUT

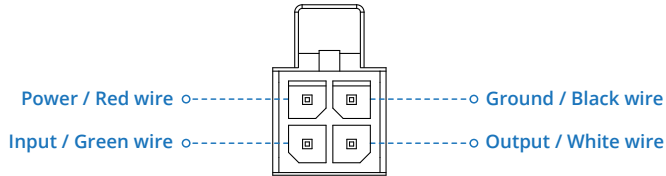

HARDWARE INSTALLATION

1. Connect the power adapter to the socket on the front of the device. Then plug the other end of the power adapter into a power outlet.
2. Connect to the device via an Ethernet cable connected to LAN port.

LOGIN TO DEVICE

1. To enter the router's Web interface (WebUI), type <http://192.168.1.1> into the URL field of your Internet browser.
2. Use login information shown in image A when prompted for authentication.
3. After you log in, you will be prompted to change your password for security reasons. The new password must contain at least 8 characters, including at least one uppercase letter, one lowercase letter, and one digit. This step is mandatory, and **you will not be able to interact with the router's WebUI before you change the password.**
4. When you change the router's password, the **Configuration Wizard** will start. The **Configuration Wizard** is a tool used to set up some of the router's main operating parameters.

A.

 **TELTONIKA**

AUTHORIZATION REQUIRED
Please enter your username
and password

admin

admin01

LOGIN

SETUP WIZARD

After logging in to the router's WebUI, you will be prompted to change the default password and the Setup Wizard will start:

1. Choose your time zone and sync the router's time with the browser if needed.

TIME ZONE SETTINGS

Current system time Thu Mar 7 14:49:06 2019 [SYNC WITH BROWSER](#)

Time zone

[SKIP](#) [NEXT](#)

2. Default LAN settings are recommended unless you have specific requirements for your LAN network.

LAN CONFIGURATION

IP address

Netmask

LAN CONFIGURATION

IP address off on

Start

Limit

Lease time

Units

[< BACK](#) [SKIP](#) [NEXT](#)

TECHNICAL INFORMATION

Bundled accessories specifications*	
Power adapter	Input: 0.6A@100-240VAC, Output: 12VDC, 1.5A, 4-pin plug

*Order code dependent.



SAFETY INFORMATION

RUTX08 router must be used in compliance with any and all applicable national and international laws and with any special restrictions regulating the utilization of the communication module in prescribed applications and environments.

[EN] English	Hereby, TELTONIKA declares that this RUTX08 is in compliance with the essential requirements and other relevant provisions of Directive RED.
[BG] Bulgarian	С настоящето, TELTONIKA декларира, че RUTX08 е в съответствие със съществените изисквания и другите приложими разпоредби на Директива RED.
[CZ] Czech	TELTONIKA tímto prohlašuje, že RUTX08 splňuje základní požadavky a všechna příslušná ustanovení Směrnice RED.
[DE] German	Hiermit erklärt TELTONIKA dass sich das Gerät RUTX08 in Übereinstimmung mit den grundlegenden Anforderungen und den übrigen einschlägigen Bestimmungen der Richtlinie RED befindet.
[DK] Danish	Undertegnede TELTONIKA erklærer herved, at følgende udstyr RUTX08 overholder de væsentlige krav og øvrige relevante krav i direktiv RED.
[EE] Estonian	Käesolevaga kinnitab TELTONIKA seadme RUTX08 vastavust direktiivi RED põhinõuetele ja nimetatud direktiivist tulenevatele teistele asjakohastele sätetele.
[ES] Spanish	Por la presente, TELTONIKA declara que este RUTX08 cumple con los requisitos esenciales y otras exigencias relevantes de la Directiva RED.
[FI] Finnish	TELTONIKA vakuuttaa täten että RUTX08 tyyppinen laite on direktiivin RED oleellisten vaatimusten ja sitä koskevien direktiivin muiden ehtojen mukainen.
[FR] French	TELTONIKA déclare que cette RUTX08 est conforme aux exigences essentielles et aux autres dispositions pertinentes de la directive RED.
[GR] Greek	ΜΕ ΤΗΝ ΠΑΡΟΥΣΑ Ο ΚΑΤΑΣΚΕΥΑΣΤΗΣ ΤΕΛΤΟΝΙΚΑ ΔΗΛΩΝΕΙ ΟΤΙ ΡUTX08 ΣΥΜΜΟΡΦΟΝΕΤΑΙ ΠΡΟΣ ΤΙΣ ΟΥΣΙΩΔΕΙΣ ΑΠΑΙΤΗΣΕΙΣ ΚΑΙ ΤΙΣ ΛΟΙΠΕΣ ΣΧΕΤΙΚΕΣ ΔΙΑΤΑΞΕΙΣ ΤΗΣ ΟΔΗΓΙΑΣ RED.
[HU] Hungarian	A TELTONIKA ezzenel kijelenti, hogy a RUTX08 típusú berendezés teljesíti az alapvető követelményeket és más RED irányelvben meghatározott vonatkozó rendelkezéseket.
[IT] Italian	Con la presente TELTONIKA dichiara che questo RUTX08 è conforme ai requisiti essenziali ed alle altre disposizioni pertinenti stabilite dalla direttiva RED.
[LT] Lithuanian	Šiuo dokumentu UAB TELTONIKA deklaruoja, kad šis RUTX08 atitinka esminius reikalavimus ir kitas RED Direktyvos nuostatas.
[LV] Latvian	Ar šo TELTONIKA deklarē, ka RUTX08 atbilst Direktīvas RED būtiskajām prasībām un citiem ar to saistītajiem noteikumiem.
[NL] Dutch	Hierbij verklaart TELTONIKA dat het toestel I RUTX08 in overeenstemming is met de essentiële eisen en de andere relevante bepalingen van richtlijn RED.
[NO] Norwegian	TELTONIKA Erklærer herved at RUTX08 er i samsvar med de grunnleggende krav og øvrige relevante krav i direktiv RED.
[PL] Polish	Niniejszym TELTONIKA deklaruje że RUTX08 jest zgodny z zasadniczymi wymaganiami i innymi właściwymi postanowieniami Dyrektywy RED.
[PT] Portuguese	Eu, TELTONIKA declaro que o RUTX08 cumpre os requisitos essenciais e outras providões relevantes da Directiva RED.
[RO] Romanian	Prin prezenta, TELTONIKA declară că aparatul RUTX08 este în conformitate cu cerințele esențiale și cu alte prevederi pertinente ale Directivei RED.
[SE] Swedish	Härmed intygar TELTONIKA att denna RUTX08 är i överensstämmelse med de väsentliga egenskapskrav och övriga relevanta bestämmelser som framgår av direktiv RED.
[SI] Slovenian	TELTONIKA izjavlja, da je ta RUTX08 v skladu z bistvenimi zahtevami in drugimi relevantnimi določili direktive RED.

The full text of the EU declaration of conformity is available at the following internet address: https://wiki.teltonika-networks.com/view/RUTX08_CE

- [EN]** Instruction Manual: Connect the power adapter to turn on the device. Open 192.168.1.1 in your web browser to configure it. More information on <https://wiki.teltonika-networks.com/>
- [BG]** Инструкции: Свържете адаптера на захранване, за да включите устройството. Отворете 192.168.1.1 в уеб браузър, за да настроите продукта. Повече информация в <https://wiki.teltonika-networks.com/>
- [CZ]** Návod k použití: Připojte napájecí adaptér k zapnutí přístroje. Otevřete 192.168.1.1 ve webovém prohlížeči pro konfiguraci produktu. Více informací najdete v <https://wiki.teltonika-networks.com/>
- [DE]** Bedienungsanleitung: Verbinden Sie das Netzteil, um das Gerät einzuschalten. Öffnen Sie 192.168.1.1 in einem Web Browser, um das Produkt zu konfigurieren. Weitere Informationen im <https://wiki.teltonika-networks.com/>
- [DK]** Instruktionsbog: Tilslut strømadapteren for at tænde for enheden. Åbn 192.168.1.1 i en webbrowser til at konfigurere produktet. Mere information i <https://wiki.teltonika-networks.com/>
- [EE]** Kasutusjuhend: Ühendage toiteadapter seadme sisselülitamiseks. Avatud 192.168.1.1 in veebilehitseja seadistada toodet. Rohkem teavet <https://wiki.teltonika-networks.com/>
- [ES]** Manual de instrucciones: Conecte el adaptador de alimentación para encender la unidad. Abra 192.168.1.1 en un navegador web para configurar el producto. Más información en <https://wiki.teltonika-networks.com/>
- [FI]** Käyttöohje: Kytke virtalähde päälle laitteen. Avaa 192.168.1.1 selaimen määräättää tuotteen. Lisää tietoa <https://wiki.teltonika-networks.com/>
- [FR]** Mode d'emploi: Connectez l'adaptateur d'alimentation pour allumer l'appareil. Ouvrez 192.168.1.1 dans un navigateur Web pour configurer le produit. Plus d'informations dans <https://wiki.teltonika-networks.com/>
- [GR]** εγχειρίδιο οδηγιών: Συνδέστε τον προσαρμογέα τροφοδοσίας για να ενεργοποιήσετε τη μονάδα. Ανοίξτε 192.168.1.1 σε ένα πρόγραμμα περιήγησης στο Web για να διαμορφώσετε το προϊόν. Περισσότερες πληροφορίες στο <https://wiki.teltonika-networks.com/>
- [HU]** Használati utasítás: Csatlakoztassa a hálózati adaptert a készülék bekapcsolásához. Megnyitása 192.168.1.1 egy webböngészőben beállítani a terméket. Több információ <https://wiki.teltonika-networks.com/>
- [IT]** Manuale di istruzioni: Collegare l'adattatore di alimentazione per accendere l'unità. Aprire 192.168.1.1 in un browser Web per configurare il prodotto. Maggiori informazioni in <https://wiki.teltonika-networks.com/>
- [LT]** Naudojimosi instrukcija: Prijunkite maitinimo adapterį, įjunkite įrenginį. Interneto naršyklėje atidarykite adresą 192.168.1.1 - galite konfigūruoti gaminį. Daugiau informacijos rasite <https://wiki.teltonika-networks.com/>
- [LV]** Lietošanas instrukcija: Pievienojiet Strāvas adapteri, lai ieslēgtu ierīci. Atvērt 192.168.1.1 ar interneta pārlūku, lai konfigurētu produktu. Plašāka informācija <https://wiki.teltonika-networks.com/>
- [NL]** Handleiding: Sluit voedingsadapter aan op het apparaat in te schakelen. Open 192.168.1.1 in een webbrowser om het product te configureren. Meer informatie in <https://wiki.teltonika-networks.com/>
- [NO]** Bruksanvisningen: Koble strømadapteren for å slå på enheten. Åpne 192.168.1.1 i en netleser for å konfigurere produktet. Mer informasjon på <https://wiki.teltonika-networks.com/>
- [PL]** Instrukcja obsługi: Podłącz adapter zasilania, aby włączyć urządzenie. Otwórz 192.168.1.1 w przeglądarce internetowej, aby skonfigurować urządzenie. Więcej informacji w <https://wiki.teltonika-networks.com/>
- [PT]** Manual de instruções: Conecte o adaptador de alimentação para ligar o aparelho. Abra 192.168.1.1 em um navegador da web para configurar o produto. Mais informações em <https://wiki.teltonika-networks.com/>
- [RO]** Instrucțiuni de utilizare: Conectați adaptorul de alimentare pentru a porni aparatul. Deschide 192.168.1.1 întrun browser web pentru a configura produsul. Mai multe informații în <https://wiki.teltonika-networks.com/>
- [SE]** Instruktionsmanual: Anslut nätadap tern för att slå på enheten. Öppna 192.168.1.1 i en webbläsare för att konfigurera produkten. Mer information på <https://wiki.teltonika-networks.com/>
- [SI]** Navodila: Priključite napajalnik za vklop naprave. Odprite 192.168.1.1 v spletnem brskalniku nastaviti izdelek. Več informacij v <https://wiki.teltonika-networks.com/>
- [SK]** Návozd na použitie: Pripojte napájací adaptér k zapnutiu prístroja. Otvorte 192.168.1.1 vo webovom prehliadači pre konfiguráciu produktu. Viac informácií nájdete v <https://wiki.teltonika-networks.com/>

For more information visit www.teltonika-networks.com



This sign means that all used electronic and electric equipment should not be mixed with general household waste.



This sign means that product meets the requirements of the applicable EU directives.